

Project:	
Type:	
Catalog #:	

STANDARD



OPTIONAL



ILLUMINATION

- Two fully adjustable, ultra bright 3.3 watt high performance MR-16 base LED lamp heads for optimized center-to-center spacing.
- Long-life, energy efficient Red or Green LED EXIT sign illumination.

ELECTRICAL

- Dual 120/277 voltage.
- Unique bi-color LED indicator light alerts occupant on battery condition (Green-normal, Red-check-battery).
- Charge rate/power "ON" LED indicator light and magnetic test switch for mandated code compliance testing.
- 6V/12V maintenance-free, rechargeable NiCd battery (12W, 15W models).
- 6V/12V maintenance-free, rechargeable sealed lead acid battery (28W model).
- Offers 4.8W, 7.8W, 20.8W of remote capacity (6V/12V DC output) standard on the 12W, 15W and 28W models.
- Internal solid-state transfer switch automatically connects the internal battery to LED board and lamp heads for minimum 90-minute emergency illumination.
- Fully automatic solid-state, two-rate charger initiates battery charging to recharge a discharged battery in 24 hours.

MOUNTING

- Universal knockout pattern on back provided with gasket for watertight seal for back mount.
- Polycarbonate mounting canopy included for top or end mount.

HOUSING

- Housing is fiberglass reinforced polycarbonate construction in gray finish.
- Corrosion-resistant enclosure with one piece, high-impact resistant, UV stabilized polycarbonate lens and molded gasket with stainless steel screws.
- Knockout's provided for conduit feed applications.
- EZ snap-out Chevron directional indicators.

OPTIONS

- SDT: Self-diagnostic feature performs monthly, biannual, and annual tests to ensure reliable operation and meets electrical and life safety codes.
- CW: Optional internal heater and battery blanket for extreme cold temperature applications (-20°C – 50°C).
- TP: Tamper-proof hardware helps discourage unauthorized access to the unit.
- NH: No lamp heads attached to the unit enabling it to be used as a remote capable EXIT sign.

WARRANTY / LISTING

- Five year warranty on all electronics and housing. Batteries prorated for two (lead acid) / five (NiCd) years.
- Meets UL924, NFPA101 Life Safety Code, NEC, OSHA, Local and State Codes.
- IP66 rated for Ingress protection.
- Rated for Class 1, Division 2, Groups A,B,C, & D.
- UL listed for wet locations (0°C – 50°C on 12W / 15W and 10°C - 40°C on 28W models).

DIMENSIONS

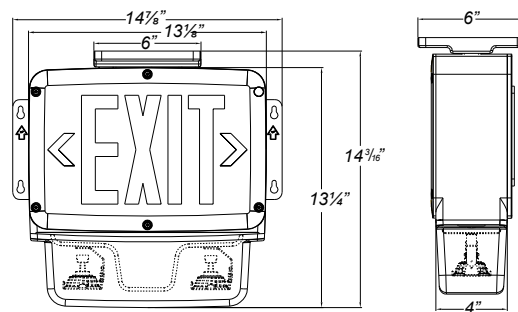

ORDERING INFORMATION

Sample Part Number: **XPESC1R615G**

MODEL	No. of FACES	LETTER COLOR	VOLTAGE	WATTAGE	HOUSING COLOR	OPTIONS
XPESC	1	Single ¹	R Red	6 6 volts	12 12 watts	SDT
	2	Double ²	G Green	12 12 volts	15 15 watts	CW
						Self-Diagnostics Cold Weather ³

¹ Available only in 15W & 28W models.