

Step-Down Transformers 347/480V to 277V



Project:	
Type:	
Catalog #:	

STANDARD



Step-down transformers are designed to utilize standard universal voltage (120-277V) electronic drivers and ballasts in applications where the main facility power is either 347V or 480V. These transformers can be used to operate multiple luminaires up to the rated maximum power, which is rated in volt-amps (VA).

FEATURES

- Operates at input voltage of either 347V or 480V ($\pm 10\%$ voltage variations) at 60Hz.
- Output voltage is 277V (single phase).
- Non-isolated autotransformer.
- Sound rated A.
- Thermally protected.
- Lead lengths are 8" (30 & 70VA models) & 14" (250 & 375VA models).

WARRANTY & LISTINGS

- UL and cUL 5085 approved.
- 5-year warranty of all electronics and housing.



DIMENSIONS

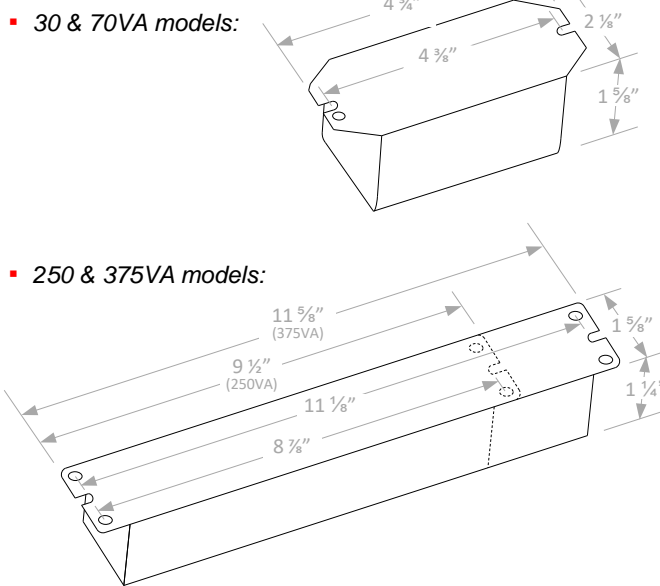

ORDERING INFORMATION

Example: KTAT-30-480-277

Model Prefix	Maximum Power (VA)	Input Voltage**	Output Voltage	Options
KTAT	30 70 250* 375	480	277	BLPSDXTX-COVER = Transformer cover box LEDPNL-EMBRKT = Mounting bracket for LED panels <i>See next page for details.</i>

* Maximum power is 180 VA @ 347V input voltage.

** Also accepts 347V input voltage.

Step-Down Transformers 347/480V to 277V



TRANSFORMER COVER BOX

- Attach transformer to cover box.
- Make wiring connections.
- Attach transformer cover box assembly to luminaire driver enclosure.

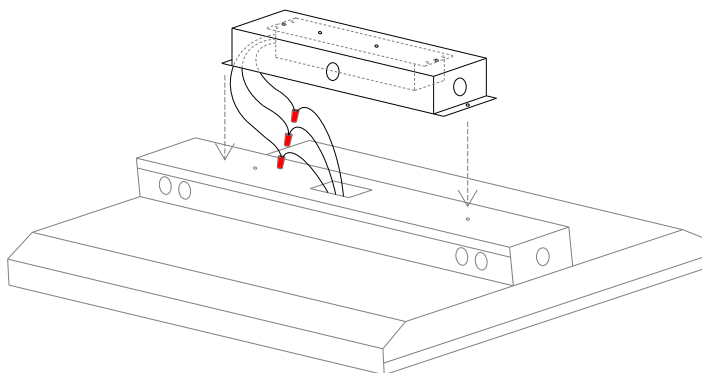

TRANSFORMER BRACKET FOR PANELS

- Attach transformer to bracket.
- Attach transformer bracket to panel.
- Make wiring connections.

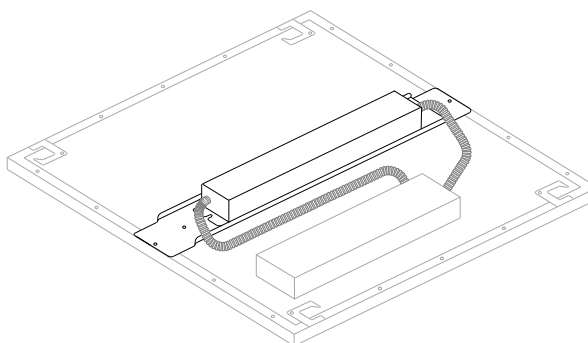

WIRING DIAGRAMS

- 30 & 70VA models:

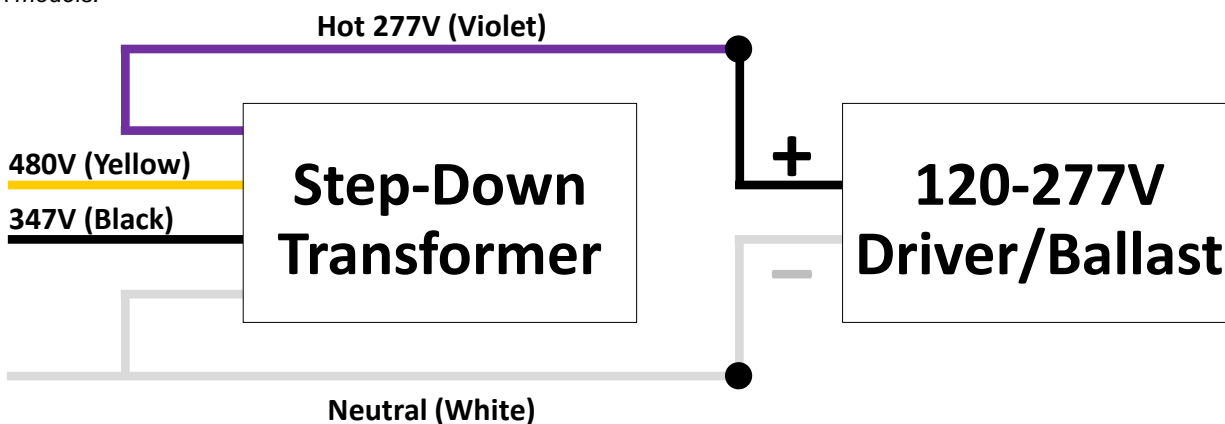

- 250 & 375VA models:

